



# SERVICE BULLETIN

## Model R Service Kit

*When performance is on the line, rely on AMOT parts!*

### Valve Overview:

AMOT Model R Thermostatic Valves are 3-way, fully automatic fluid temperature controllers. These valves are suitable for process control and industrial applications where fluids must be mixed or diverted depending on their temperatures. They are used for reliable, automatic control of fluid temperatures in turbines, compressors and engine jacket water and lubricating oil cooling systems, as well as cogeneration systems.



### Maintenance & Servicing:

When properly applied and installed, AMOT Model R Thermostatic Valves require minimal maintenance. Field adjustments are not required as the operating temperature of each valve is permanently set at the factory by trained technicians. Once installed, this valve will provide years of trouble-free service.

The Model R Thermostatic Valve is currently offered as Model RO. Previous R models included RF and RT.

First, identify your valve model, located on the valve nameplate. An example is shown below for a RO valve with model number RO40SY120060-RNB

Over time, exposure to foreign chemicals and particulate matter as well as prolonged operation at extreme temperatures, pressures and flows may reduce the effectiveness of your control valve. At such time, AMOT thermostatic valves can be restored to original performance simply by installing an AMOT Thermostatic Valve Service Kit. Service Kits include all new thermostatic elements and seals and can be easily installed by unbolting the valve housing.

Example Model RO Valve:

A	B	C	D	E	F	G	-H
RO	40	S	Y	120	06	0	-RNB

A – Valve Family  
 B – Size  
 C – Body Material  
 D – Connection Type  
 E – Temp (°F)  
 F – Element/Seal Material  
 G – Leak Hole  
 H – Special

For Service Kits numbers corresponding to Model RO, use the valve model, except replace the Body Material (C) and Connection (D) with “KIT-“. The corresponding service kit becomes:

A	B	C	D	E	F	G	-H
RO	40	KIT-		120	06	0	-RNB

*AMOT recommends servicing of thermostatic control valves with each regularly scheduled major overhaul of your turbine, engine, compressor or other associated equipment.*

In addition, some AMOT valves will contain “-AA” in the suffix location (H). This suffix should be omitted from the Service Kit number.

Thermostatic Service Kits may also be used for adapting valves to new service temperatures.

Additional examples as follows:

### Service Kit Identification:

AMOT Thermostatic Valve Service Kit model numbers closely follow the valve model numbers for which they are associated.

Valve Model	Corresponding Service Kit
RO25SX150060	RO25KIT-150060
RO50SX160063	RO50KIT-160063
RO65SY130030-RNB	RO65KIT-130030-RNB
RO25SY170060	RO25KIT-170060
RO65SY140060	RO65KIT-140060
RO20SX110060-AA	RO20KIT-110060

An example is shown below for a RF/RT valve with model number RF5BSAEN-RNB

Example Model RF/RT Valve:

A	B	C	D	E	F	G	-H
RF	5	B	S	A	E	N	-RNB

A – Valve Family  
B – Size  
C – Connection Type  
D – Body Material

E – Element/Seal Material  
F – Temp (°F)  
G – Leak Hole  
H – Special

For the corresponding Model R Service Kit, use the valve model except replace the Body Material (C) and Connection (D) with “KIT-“. The corresponding service kit becomes:

A	B	C	D	E	F	G	-H
RF	5	KIT-		E	E	N	-RNB

Additional examples as follows:

**Valve Model**  
RF5BSAEN-RNB  
RF6ASAH3  
RT6BSBEN-RNB  
RT5BSAEN

**Corresponding Service Kit**  
RF5KIT-AEN-RNB  
RF6KIT-AH3  
RT6KIT-BEN-RNB  
RT5KIT-AEN

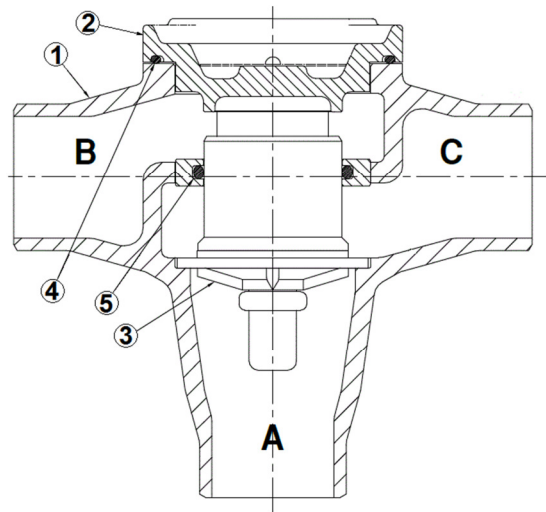

**Model R Service Kit Installation:** The following instructions are for servicing the valve while isolated in a cool, non-operational system. Consult the Primary Equipment OEM’s Operation and Maintenance Manual for instructions on locking out equipment and isolating the valve.

- 1) Remove Bolts and separate the Cover/Element Cartridge ② and Sleeve O-Ring ④ from the valve body ①.
- 2) Remove Element Assembly ③ and Element O-Ring ⑤. **Note:** Model RO80, RF8 and RT8 each have two sets of elements per valve.
- 3) Lubricate new Element O-Ring Seal ⑤ with a good grade of petroleum grease and install the O-Ring in the groove in the valve body.
- 4) Insert Element Assembly ③ through Element O-Ring ⑤ of the cartridge with a twisting motion.
- 5) Install housing seal O-Ring ④ and bolt on the valve Cover/Element Cartridge ②.

#### Americas

AMOT Americas  
8824 Fallbrook Dr  
Houston, TX 77064 USA  
Tel +1 (281) 940 1800  
Fax +1 (713) 559 9419  
Email: sales@amotusa.com

#### Asia Pacific

AMOT Asia Pacific  
RM 4102 - 4104 United Plaza  
1468 Nanjing Road West  
Shanghai 200040 China  
Tel: +86 (0) 21 6279 7700  
shanghai@amot.com

#### Europe, Middle East & Africa

AMOT UK  
Western Way  
Bury St Edmunds  
Suffolk, IP33 3SZ, United Kingdom  
Tel: +44 (0) 1284 762222  
info@amot.com